



# Mast Arm Base

From: **ALLOY CASTINGS CO., INC.**  
*Quality Aluminum Castings Since 1948*

151 West Union Street • P.O. Box 473 • East Bridgewater, MA 02333-0473  
 Telephone: (508) 378-2541 • FAX: (508) 378-1240  
 www.alloycastings.com

## Mast Arm Base

### Material Specifications

Aluminum Alloy 356 (ASTM SG70A)  
 Conforming to ASTM Spec B26 for Sand Castings  
 with Minimum Yield

STRENGTH: Tension: 18KSI  
 Compression: 19KSI  
 Shear: 17KSI

**All hardware 304 Stainless Steel.**  
**Base contains internal grounding stud.**

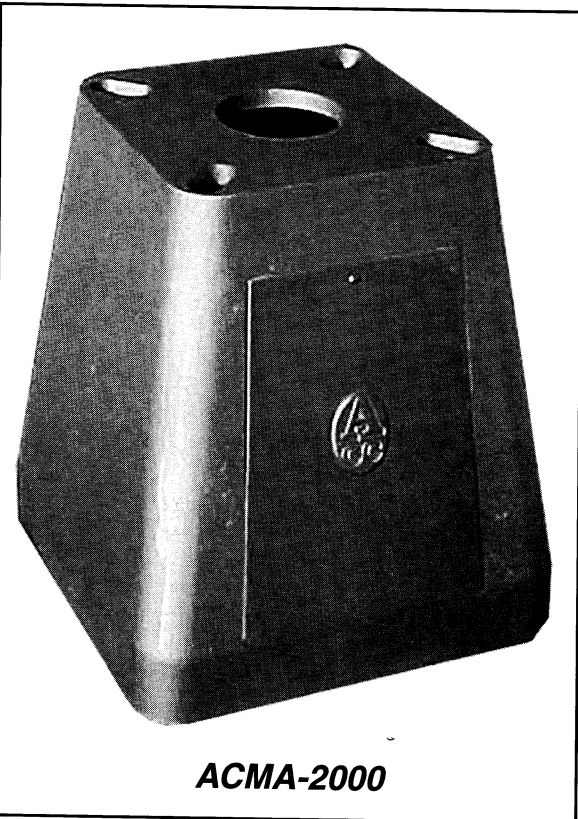

**ACMA-2000**

**ELEVATION**

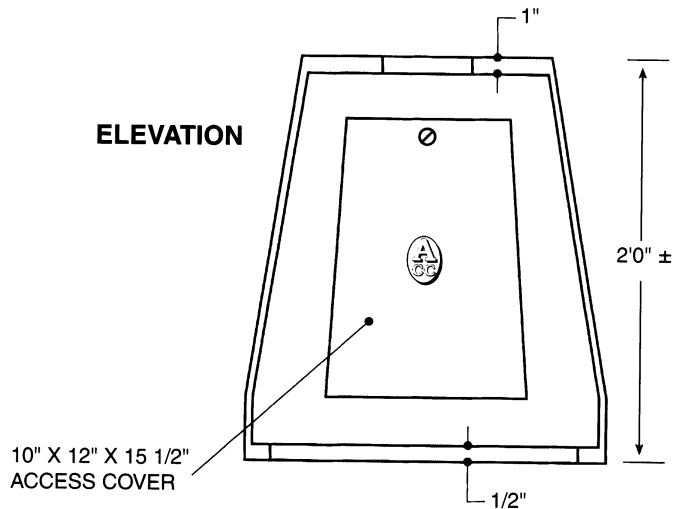

20-22" DIA. ± BOLT CIRCLE  
 FOR 3/4" ANCHOR BOLTS

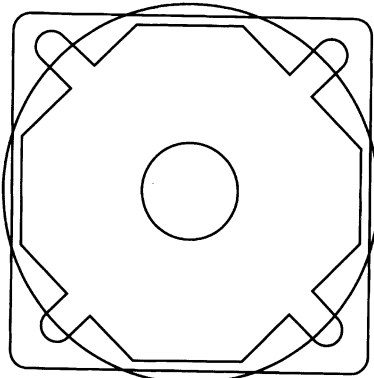

1-9 3/8" ±  
 BOLT CIRCLE: 18 TO 22" DIA.

**BOTTOM PLAN**

BOLT CIRCLE  
 FOR 3/4" BOLTS

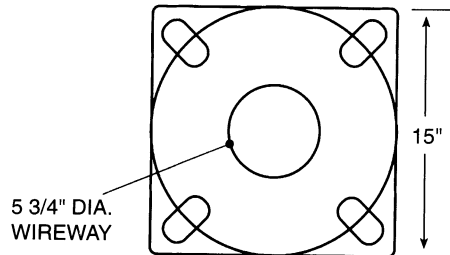

5 3/4" DIA.  
 WIREWAY

BOLT CIRCLES: 10" TO 12" DIA., 15" TO 17" DIA.

**TOP PLAN**

**OTHER BOLT CIRCLES AVAILABLE UPON SPECIFICATION**